

NOTE: DO NOT DISCARD the Parts List from the Instruction Bulletin. Place the Parts List in the appropriate place in the machine manual for future reference. Retaining the Parts List will make it easier to reorder individual parts and will save the cost of ordering an entire kit.

NOTE: Numbers in parenthesis () are reference numbers for parts listed in Bill of Materials.

Installation instructions for **kit number 9008193**

SYNOPSIS:

This kit contains the parts needed to replace the vaporizer on M20 / M30 / T20 / S30 / 800 / 550 machines equipped with Mitsubishi 2.0 LPG engines or GM 3.0 LPG engines.
 Please follow step-by-step instructions.

SPECIAL TOOLS / CONSIDERATIONS: NONE

(Estimated time to complete: 40 minutes)



PROTECT THE ENVIRONMENT

Please dispose of packaging materials, used machine components such as batteries and fluids in an environmentally safe way according to local waste disposal regulations.

Always remember to recycle.

PREPARATION:

FOR SAFETY: Before leaving or servicing machine, stop on level surface, turn off machine, set parking brake, and remove key.

FOR SAFETY: When servicing machine, keep flames and sparks away from fuel system service area. Keep area well ventilated.

1. Close the LPG tank service valve. (Fig. 1)

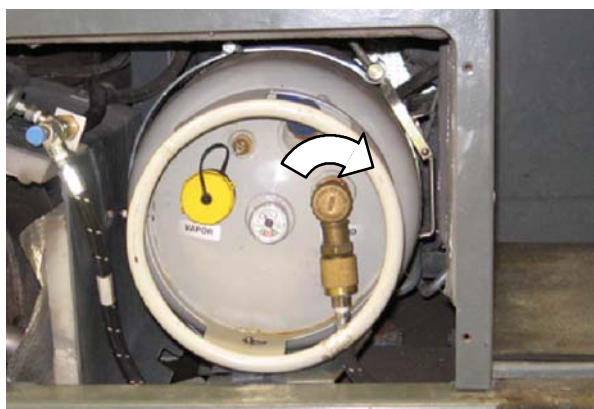

FIG. 1

2. Start the machine and allow it to run until the engine stops. Attempt to restart the machine again to ensure all fuel has been run from the fuel lines.
3. Disconnect the battery cables from the batteries.



WARNING: Always disconnect battery cables from machine before working on electrical components.

4. Open covers / doors to access the engine compartment and locate the LPG vaporizer. (Fig. 2 / Fig. 3 / Fig. 4 / Fig. 5)

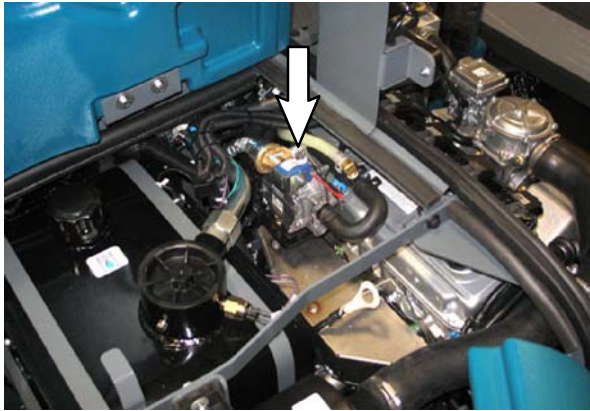

FIG. 2 - S30

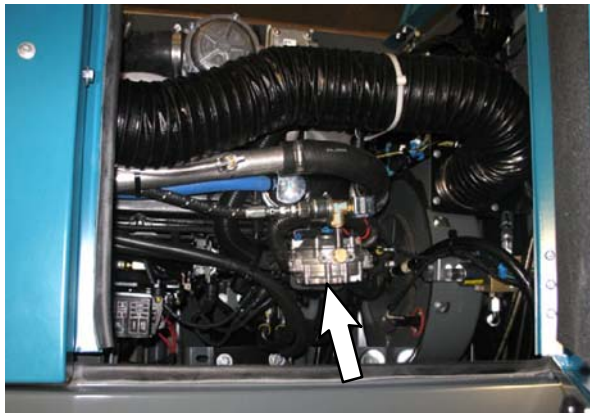

FIG. 3 - 800

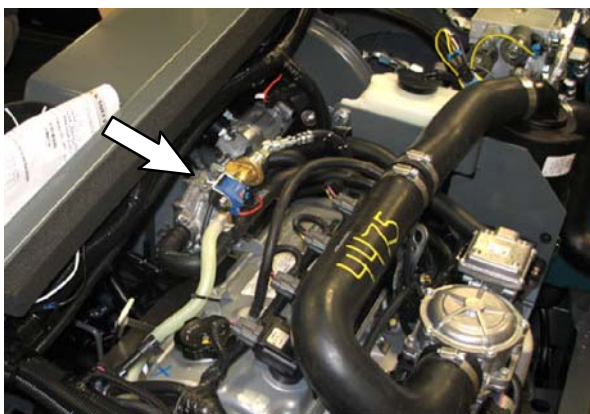

FIG. 4 - M20 / M30 / T20

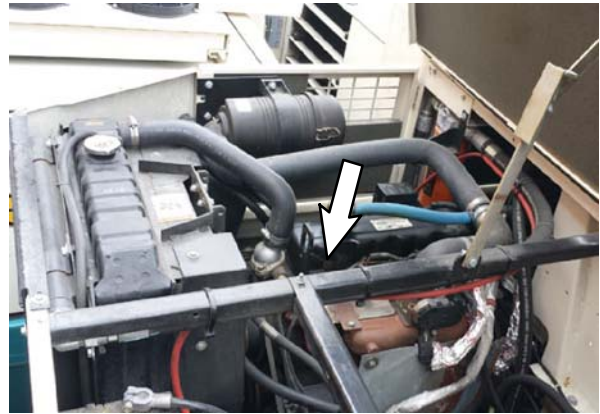

FIG. 5 - 550

5. Loosen the LPG line at the lock off to allow any remaining fuel to drain from the line. (Fig. 6)

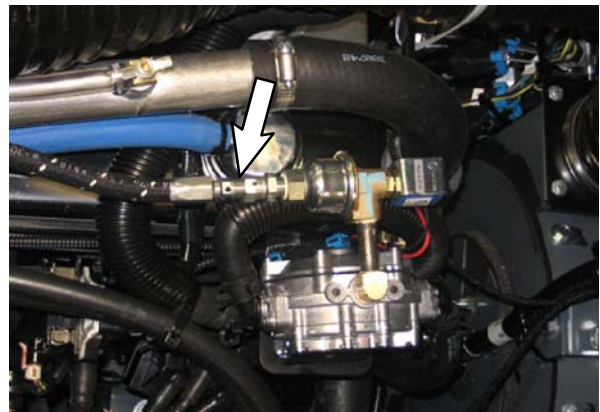

FIG. 6

6. Remove the radiator cap from the radiator to relieve pressure from the coolant system. Reinstall the radiator cap.

FOR SAFETY: When servicing machine, avoid contact with hot engine coolant. Do not remove cap from radiator when engine is hot. Allow engine to cool.

INSTALLATION:

1. Disconnect the main harness from the lock off assembly. (Fig. 7)

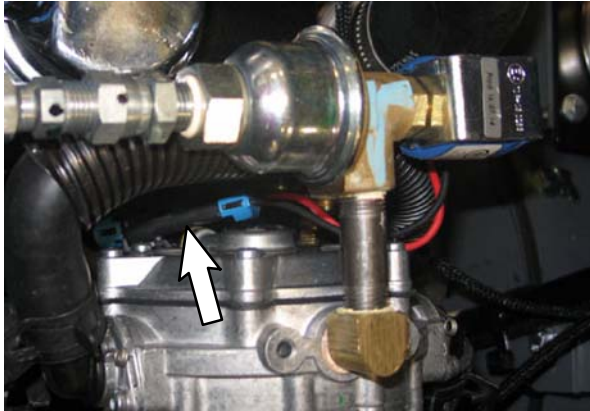

FIG. 7

2. Use pinch clamps to pinch the coolant hoses connected to the vaporizer. (Fig. 8)

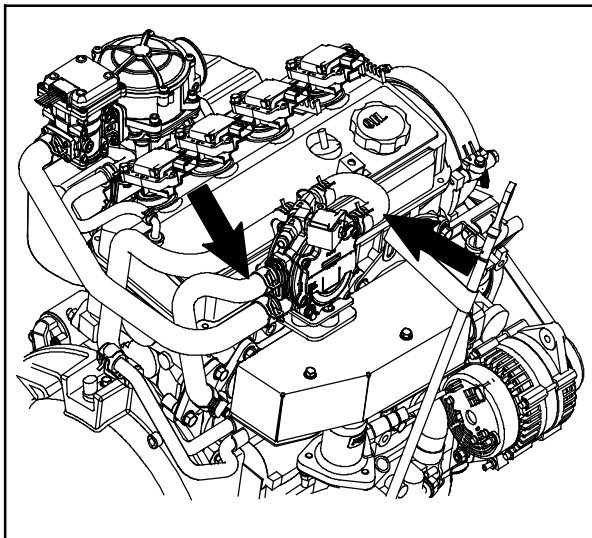

FIG. 8

3. Remove the clips securing the hose fittings to the vaporizer and disconnect both coolant hoses and the LPG line from the vaporizer. Set the clips aside. (Fig. 9 / Fig. 10)



FIG. 9

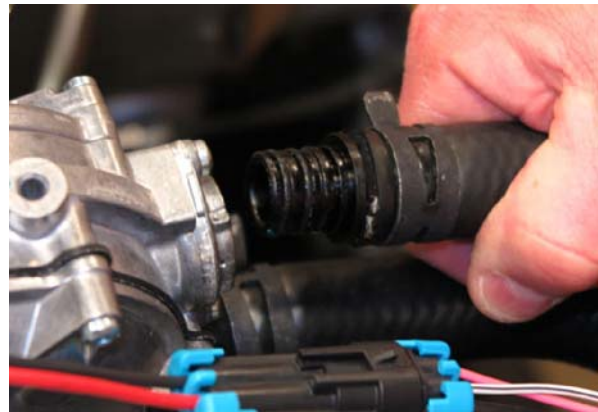

FIG. 10

4. Remove hardware securing the vaporizer / mounting plate to the mounting bracket. Set the hardware aside. (Fig. 11)

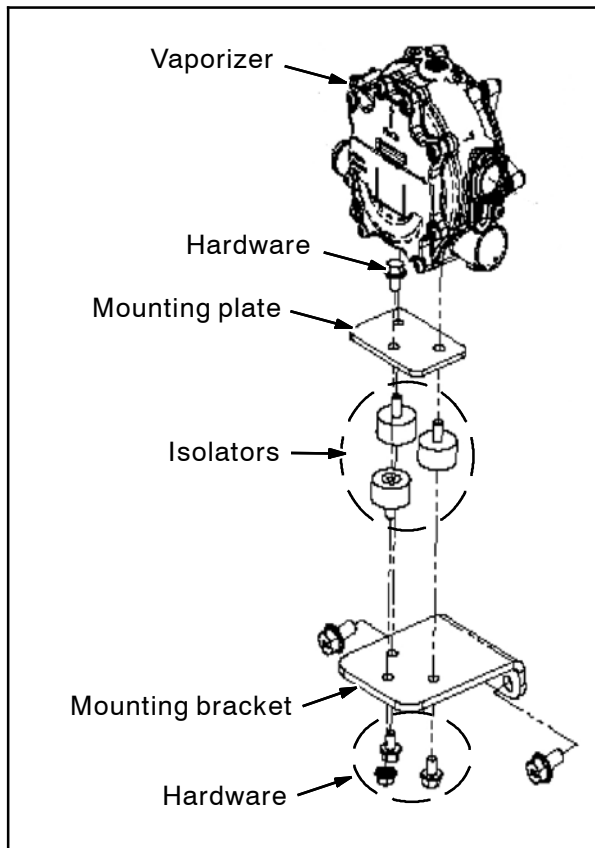

FIG. 11

5. Firmly secure the mounting plate attached to the vaporizer into a bench vise. (Fig. 11)

6. Remove the lock off assembly from the vaporizer. Set the lock off assembly aside. (Fig. 12)

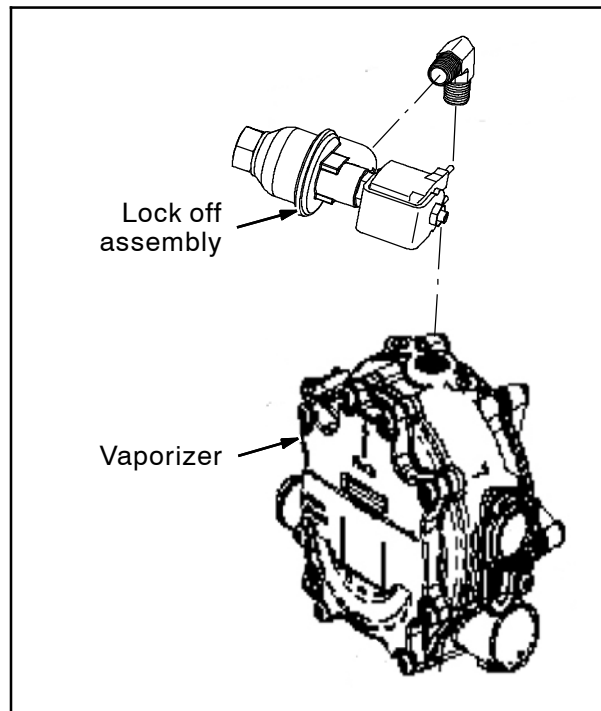

FIG. 12

7. Remove the mounting plate / vaporizer from the bench vise and remove the mounting plate from the vaporizer. Set the mounting plate, isolators, and hardware aside. (Fig. 11)
8. Mark the removed vaporizer as defective so it cannot be mistaken as a good vaporizer.

- Use Loctite® 7649 to clean all residue from the threaded portion of the lock off assembly fitting previously attached to the defective vaporizer. (Fig. 13)

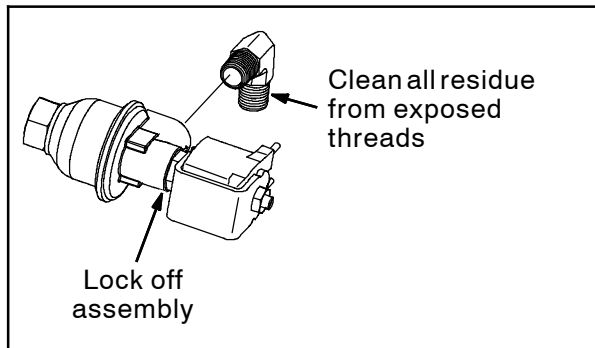

FIG. 13

- Inspect the new vaporizer (1). There must be an orange dot located below the two green dots on the fuel input end of the vaporizer. The vaporizer must have a serial number greater than 280000. Letters E through Z (Rev. E - Rev. Z) must be at the end of the part model number. (Fig. 14 / Fig. 15)

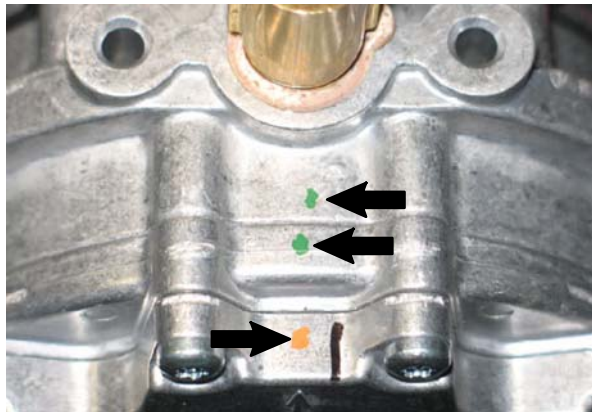

FIG. 14



FIG. 15

- Apply a coat of Loctite 567 thread sealant onto the exposed threaded portion of the fitting on the lock off assembly. (Fig. 13)
- Install the lock off assembly onto the new vaporizer (1). (Fig. 12)
- Install the mounting plate / isolators onto the vaporizer (1). (Fig. 11)
- Install the vaporizer (1) / mounting plate onto the mounting bracket. (Fig. 11)
- Apply o-ring lubricant onto the o-rings on the hose fittings. (Fig. 16)



FIG. 16

- Reconnect the coolant hoses and LPG line to the vaporizer (1) and reinstall the clips to secure the hoses / fittings in the vaporizer. Remove the pinch clamps installed from the hoses. (Fig. 17)

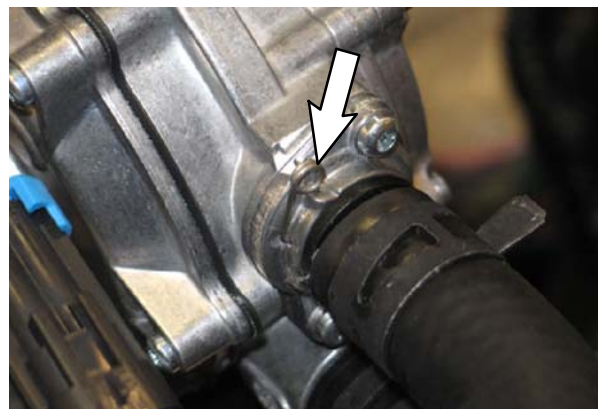

FIG. 17

- Reconnect the main wire harness to the lock off assembly.

18. Start and test the machine. Apply a soap / water mixture around the area where the lock off fitting is installed on the vaporizer and observe the connection for leaks. (Fig. 18)

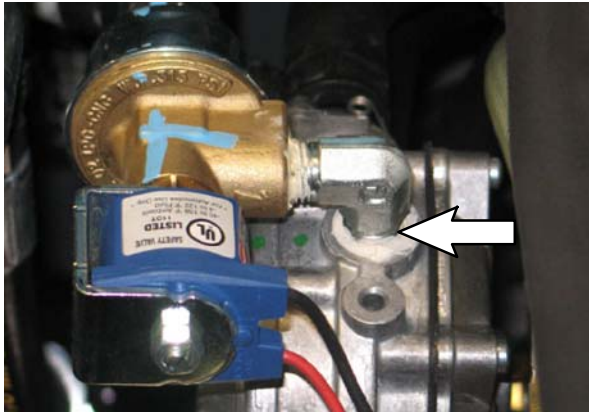

FIG. 18

Bill Of Materials For VR, Regulator [GM3.0L 2010/MIT] - 9008193

	Ref.	Tennant Part No.	Description	Qty.
▽		9008193	VR, Regulator [GM3.0L 2010/MIT]	1
▲	1	000000	Vaporizer	1

TENNANT COMPANY
P. O. Box 1452
Minneapolis, MN 55440-1452